

TMC[®]

Engineered to move

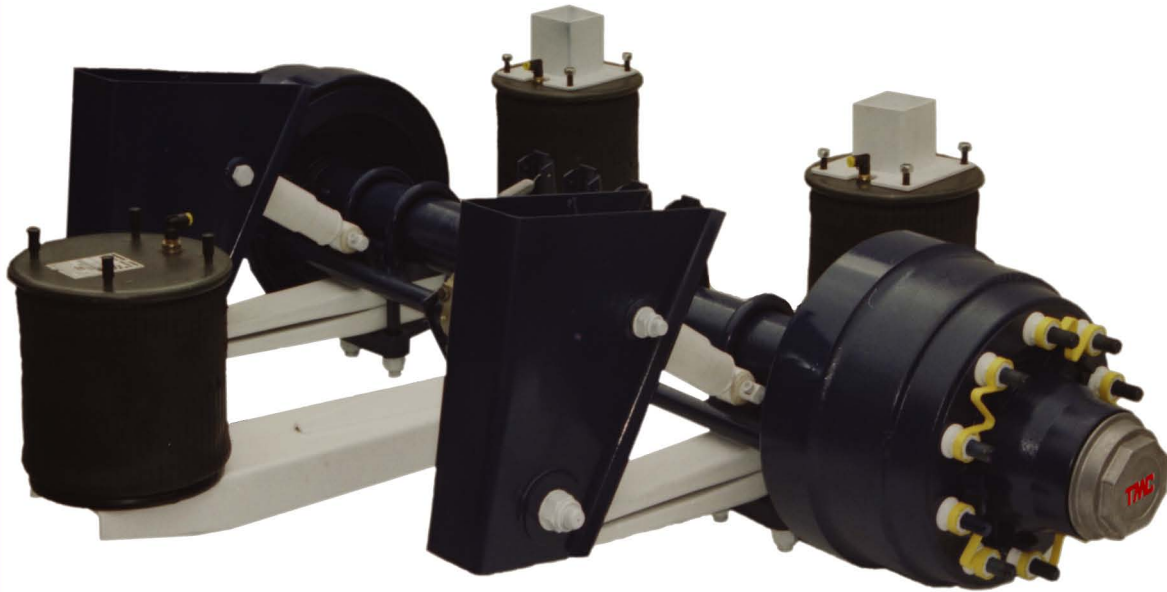
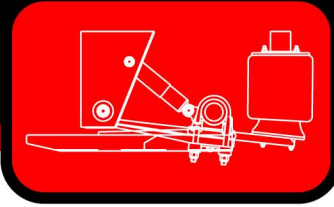
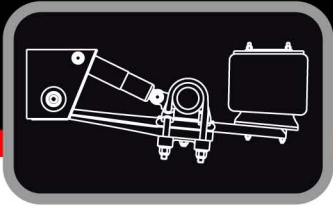

- ✓ Long life pivot bush
- ✓ Heavy duty shock absorber
- ✓ Bump stop built into air springs
- ✓ Available in unit module
- ✓ Extra strong leaf-spring support

ARS SERIES

TMC ARS SERIES Air Suspensions Module offers superior performance, reliability, and air-ride quality whether on city roads or outback tracks.

TMC ARS is factory assembled to guarantee correct fit-up, offering components with easy accessibility and low maintenance.

AIR SUSPENSION

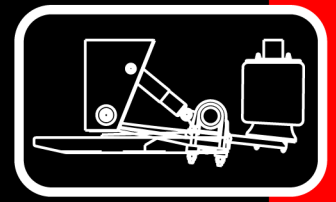
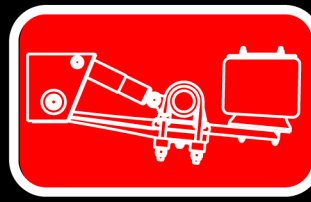

TMC ARS AIR SUSPENSION STANDARD SPECIFICATION

Capacity	12 Tonne per Module
Ride Height	Available from 200mm through to 400mm
Mounting Centres	965 Dual Wheel Axles
Air Bag Centres	800 Dual Wheel Axles
Spring	Suits 127mm diameter Axles
Tare Weights	12 Tonne Module 400 Ride Height = 225kg (Approx.)

Options

- Axle lift 90mm lift standard
- Centre or side lifts available
- Full range of pneumatic kits

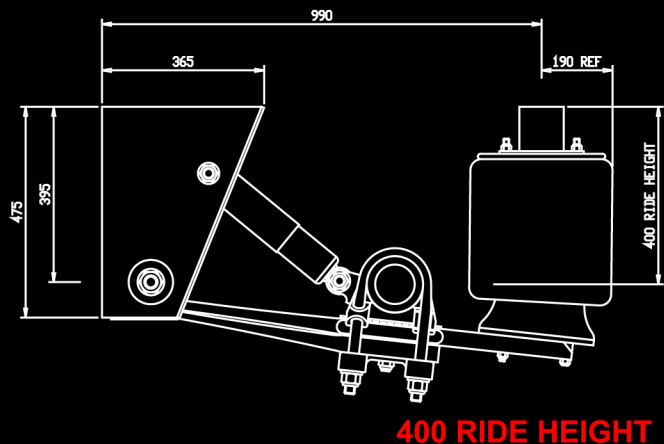
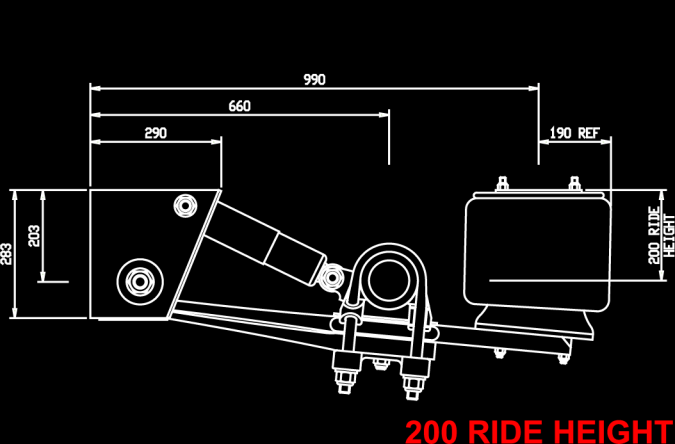
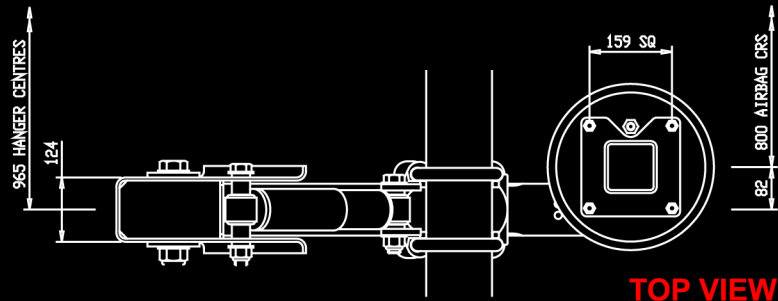

TMC Australia Pty Ltd.
78 Star Crescent, PO Box 5028, Hallam,
Victoria 3803, Australia.
Ph 03 8786 3688, Fax 03 8786 3699,
Email info@tmcaus.com.au

TMC Axle Manufacturing Sdn Bhd.
No 79 & 80 Jalan 5/10B, Spring Crest
Industrial Park, 68100 Batu Caves, Kuala
Lumpur, Malaysia.
Ph 03 6187 7788 Fax 03 6187 6722
Email info@tmc.com.my
Web www.tmc.com.my

TMC Transport Equipment (Asia) Pte. Ltd.
No. 21, Toh Guan Road East,
Toh Guan Centre, #05-28,
Singapore 608609
Telephone: (65) 63162685
Fax: (65) 63162685
Email: khdtan@singnet.com.sg

Wuhan TMC Axle Corporation Ltd
Lianhu Road, Wuhan Economi &
Technological Development Zone,
Hubei, 430056, China
Tel: (86) 2784472588, 84472676
Fax: (86) 2784291519
Email: tmcwh@china.com